

We reserve the right to make technical changes without prior announcement. All rights reserved.
©2021 GENOX USA, LLC

Z Series

Vertical Shredder



GENOX USA, LLC.
740 4th Street N, #156
Saint Petersburg, FL 33701
Tel: +1 724-960-1146
e-mail: sales@genoxusa.com



www.genoxusa.com



Vertical Shredder

Z Series

Z series vertical shredders are mostly recommended for applications processing pre-shredded metal scrap from twin shaft shredding systems. These machines aggressively size reduce and densify pre-shredded material whilst liberating the various different fractions, allowing for better separations and reduced transportation costs.

The breakers in the upper part of the chamber smash the material until it is small enough to enter the gap between the milling rings and chamber liners. When the material enters the second stage the milling rings impact, grind and roll the material into clean, dense nuggets. When milled in to small enough pieces, the balled-up material falls into the lower chamber and is ejected by the discharge paddles. The three above stages create a product which is both clean and of high bulk density suitable for transportation.

Z Series			
MODEL	Z1500	Z3500	Z6000
Dimension (L x W x H) (mm)	3300 x 3800 x 5000	5300 x 4650 x 6450	5500 x 4750 x 6600
Rotation Speed (RPM)	680	540	500
Chamber Diameter (mm)	Ø 1140	Ø 1560	Ø 1680
Chamber Height (mm)	1680	1785	1890
Number of Breakers (PCS)	2	2	2
Number of Rings (PCS)	36	64	64
Number of Liners (PCS)	12+12	12+12	12+12
Main Drive (kw)	110	132+132	220+220
Hydraulic Power Pack (kw)	1.5	2.25	2.25
Weight (kg) ~ Approx	14500	30000	45000

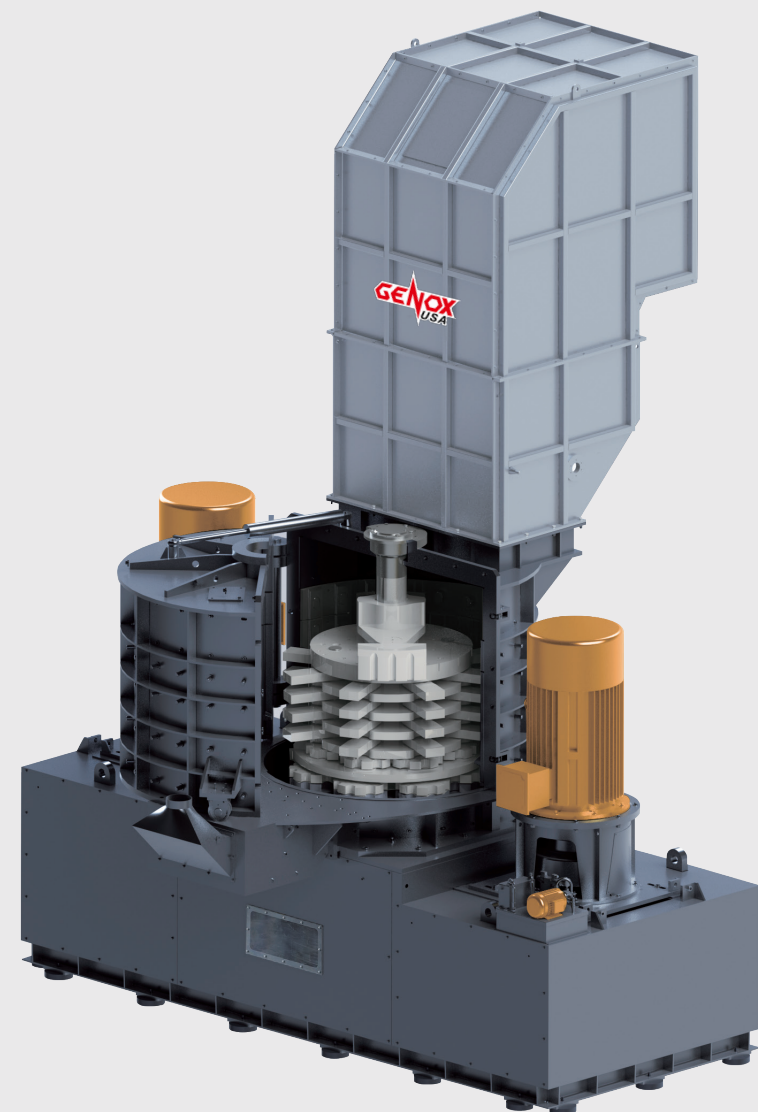

Chamber Liners
Durable, wear resistant, replaceable chamber liners for long service life.

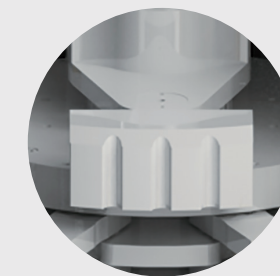

Hammer Breaker
Heavy duty hammer breaker for smashing material.

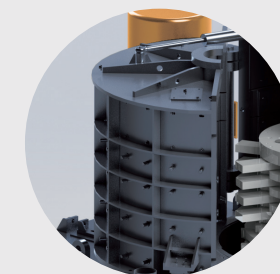

Explosive-proof Hatch
EU approved explosive-proof, preventing damage caused by explosion.

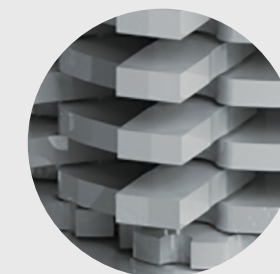

Hammer Mill
Optional hammer plates equipped for smashing bulky materials and liberating different types of materials.

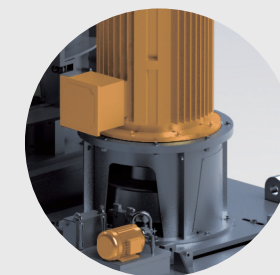

Drive System
Equipped with fluid coupling to improve performance and reduce current during start-up. Optional VFD device for machine rotating speed control.

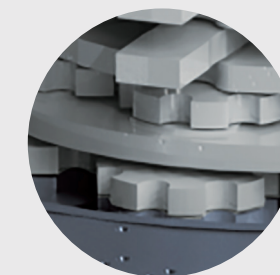

Ring Mill
Optional ring mill equipped for grinding and rolling the material into clean, dense nuggets suitable for transportation.



more info