

We reserve the right to make technical changes without prior announcement. All rights reserved.
©2021 GENOX USA, LLC

Tire Recycling System

Our system solutions cover a wide range of recycling applications.
Genox USA specializes in providing customized designs for your specific recycling projects.



www.genoxusa.com



GENOX USA, LLC.
740 4th Street N, #156
Saint Petersburg, FL 33701
Tel: +1 724-960-1146
e-mail: sales@genoxusa.com



Tire Recycling System

Features

- 1 The pre-shredding system can be equipped with bolted cutting tools to minimize the operational cost and simplify maintenance of the line.
- 2 Two-stage rasper system effectively liberates the steel from the rubber enabling effective separations and the production of clean wire.
- 3 The fine granulation system is equipped with a special rotor designed specifically for tire rubber sizedreduction. It provides maximum throughput, whilst minimizing the amount of fines created. The machine is also optimized for low operational and wear costs.
- 4 Textile and dust is aspirated at several positions of the recycling system.

- 5 A central Reverse Jet Filtration System extracts and contains dust from the entire system.
- 6 System automation ensures that components actions are linked, the system capacity is maximized, and the system is protected against interfering material in the best way.

Applications

- Car & commercial tires
- Truck tires
- O.T.R. tires

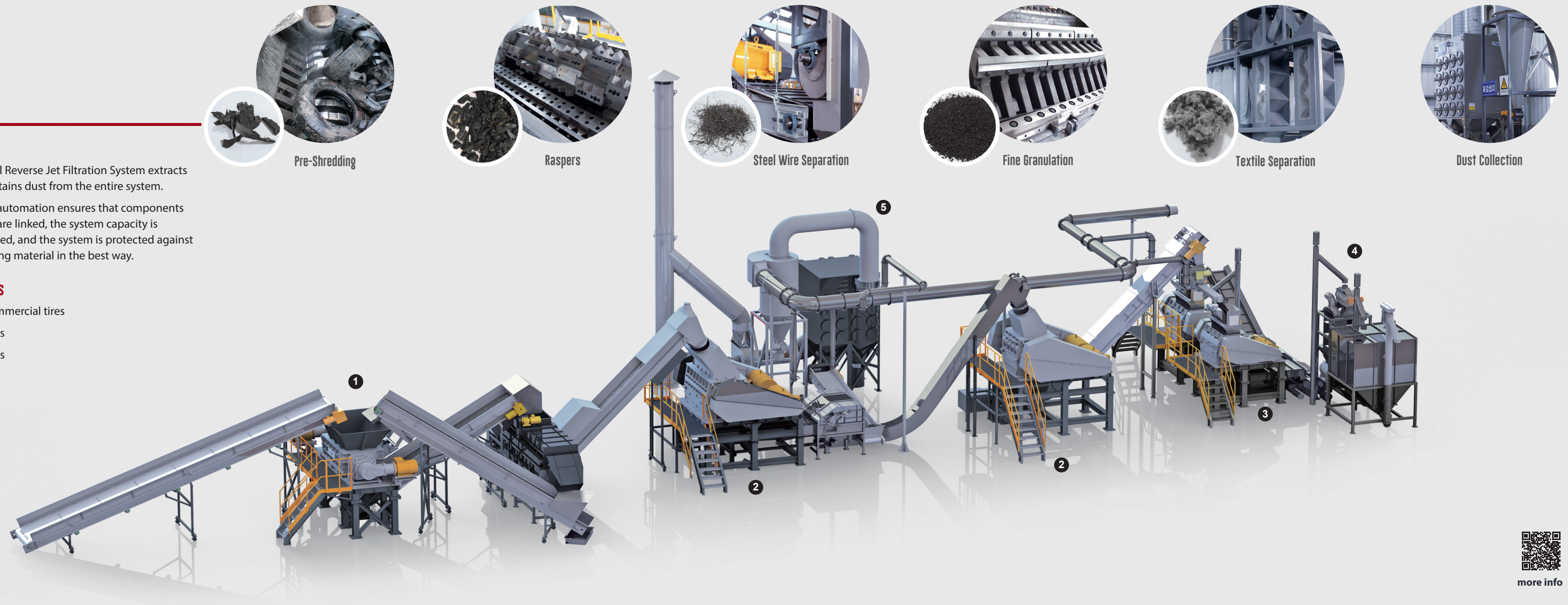

more info